

# Lindab **Safe and** Lindab **Safe Click**

Mounting instruction

# Mounting instruction

# Lindab Safe

## Eurovent certification

Lindab's circular duct system with rubber gasket connections Lindab Safe and Lindab Safe Click is certified to strength and leakage in tightness class D according to the Eurovent Certified Performance program for circular metallic ducts systems (DUCT-MC 17.11.002).



Lindab products that are Eurovent certified have the Eurovent logotype in the footer of the technical documentation.

Note: Most Lindab Safe and Lindab Safe Click and the most commonly used product in a ventilation system are essentially better than class D, however some products are according to EN 15727 not class D as a single product. These products are stated in the documentation as Class C and can be used in D class systems to a limited extent.

# Mounting instruction

# Lindab Safe

## Content

Eurovent certification .....	2
Overview.....	4
Storage.....	5
Preparations for assembly .....	5
Joining systems (general characteristics) .....	5
Position and number of notches and fasteners.....	6
Table 1. Positioning of the new notches .....	6
Table 2. Number of fasteners and notches .....	6
Table 3. Recommended sizes of fasteners .....	6
Assembly .....	7
Table 4. Screws and blind rivets .....	8
Hints!.....	8
Before final assembly.....	9
Dismantling.....	10
Products with special seals .....	10
Products without Click.....	10
Use of products other than Lindab Safe or Lindab Safe Click.....	10

# Mounting instruction

# Lindab Safe

## Overview

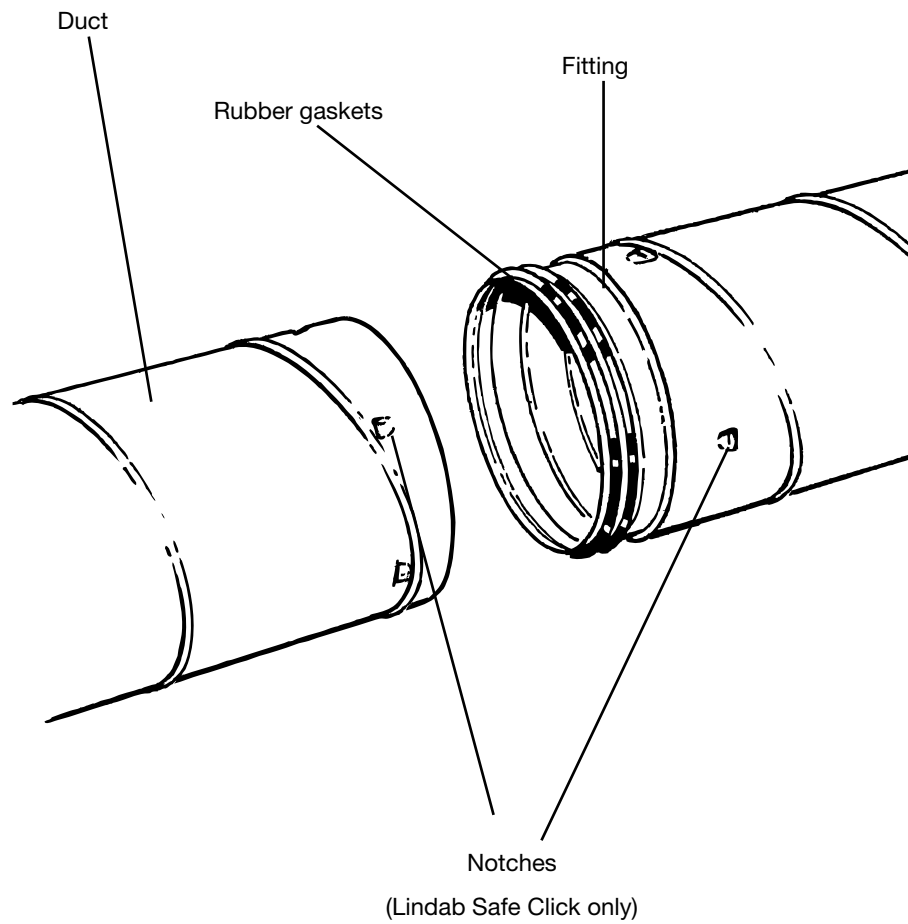

# Mounting instruction

# Lindab Safe

## Joining systems (general characteristics)

Lindab Safe	Lindab Safe Click
Joined with screws or blind rivets.	Joined with snapping heels, below called notches. Is based on and can be used with Lindab Safe.
Spans all dimensions.	Spans only a number of dimensions, see table 2. For any other dimensions use Lindab Safe.
	<p>Lindab Safe Click can be complementary joined with screws or blind rivets, this may be done in order to:</p> <ul style="list-style-type: none"> <li>• achieve a stronger joint</li> <li>• prevent a joint from twisting</li> <li>• join a Click product with a non-Click product</li> <li>• join a Click product with a non-Click product to create an openable joint</li> </ul>

## Storage

Store ducts and fittings in a well-ordered and weatherproof storage area to minimize the risk of damage.

NOTE! Do not use ducts or fittings that have been damaged in such a way that they jeopardise the air tightness or structural strength of the system.

## Preparations for assembly

Lindab Safe	Lindab Safe Click
<ul style="list-style-type: none"> <li>• Cut ducts at right angles. Carefully remove any burrs from cut edges to make installation easier and reduce the risk of damaging the rubber gasket.</li> <li>• Cut away the two needles created from the fold.</li> </ul>	<ul style="list-style-type: none"> <li>• Cut ducts at right angles, this is an uncompromisable demand for Lindab Safe Click. Carefully remove any burrs from cut edges to make installation easier and reduce the risk of damaging the rubber gasket.</li> <li>• Cut away the two needles created from the fold.</li> </ul>
<ul style="list-style-type: none"> <li>• Carefully seal any holes left by measurements, removed screws, blind rivets, etc.</li> </ul>	<ul style="list-style-type: none"> <li>• If a duct is cut – make new notches around its circumference. See table 1 and 2.</li> <li>• Carefully seal any holes left by measurements, removed screws, blind rivets, etc.</li> </ul>



# Mounting instruction

# Lindab Safe

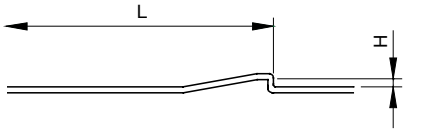

## Position and number of notches and fasteners

**Table 1. Positioning of the new notches**



	Click Pliers		L [mm]
	40.1	60.1	
			
Ø [mm]	Hmin [mm]	Hmin [mm]	L [mm]
80–224	2,0	–	30,5–32,5
250–315	–	2,5	50,5–52,5

**Table 2. Number of fasteners and notches**

Ø [mm]	Lindab Safe	Lindab Safe Click	
	Minimum number of <b>fasteners</b> required to achieve sufficient strength.	Click Pliers	
		40.1	60.1
			
Ø [mm]	Minimum number of <b>fasteners</b> required to achieve sufficient strength.	Minimum number of <b>notches</b> required to achieve sufficient strength.	
63	2	–	–
80–112	2	2	–
125–160	3	4	–
180–224	3	4	–
250–315	4	–	4
355–630	4	–	–
710–1250	6	–	–
1400–2000	10	–	–

NOTE! A larger number of notches will make it harder to assemble the parts

**Table 3. Recommended sizes of fasteners**

Dim [mm]	Screw		Blind rivet	
	Lenght [mm]	Diameter [mm]	Lenght [mm]	Diameter [mm]
63-250	9,5	4,2	8	3,2
250-630	13	4,2	9,5	4
710-1250	13	4,2	9,5	4,8
1400-2000	16	4,8	9,5	4,8

# Mounting instruction

# Lindab Safe

## Assembly

Lindab Safe	Lindab Safe Click
<p>1 Insert the fitting's turned-over edge into the duct.</p> <p>NOTE! Check that the rubber gasket's first lip is in contact with the duct's edge all the way around and points straight out so that the lip is not twisted in any direction.</p>	<p>1 Insert the fitting's turned-over edge into the duct.</p> <p>NOTE! Check that the rubber gasket's first lip is in contact with the duct's edge all the way around and points straight out so that the lip is not twisted in any direction</p>
<p>2 Push the rest of the fitting into the duct. Twisting the fitting slightly aids insertion.</p>	<p>2 Push the first part of the fitting into the duct to just before the notches. Twisting the fitting slightly aids insertion.</p>
<p>3 Secure the fitting in the duct using self-tapping screws or airtight blind rivets.</p> <p>NOTE! When aiming for tightness class C or D, only use screws or blind rivets allowed by Lindab, see table 3.</p>	<p>3 Push the rest of the fitting into the duct and over the notches. Bend the fitting or duct back and forward slightly in order not to pass all notches at the same time aids insertion.</p>
<p>4 Fasteners should be positioned 10–15 mm from the duct's end to prevent damage to the gasket.</p>	<p>4 The fitting is secured to the duct when the fitting's end has snapped behind all the notches.</p>
<p>5 Always position fasteners at the present largest radial gap between fitting and duct. Be sure to achieve an even distribution around the circumference.</p>	<p>5 After assembly it's possible to rotate the fitting.</p>

HINT! Carefully tapping the surface of the duct with your hand makes assembly easier, as it reduces the friction between duct and fitting.

Lindab Safe

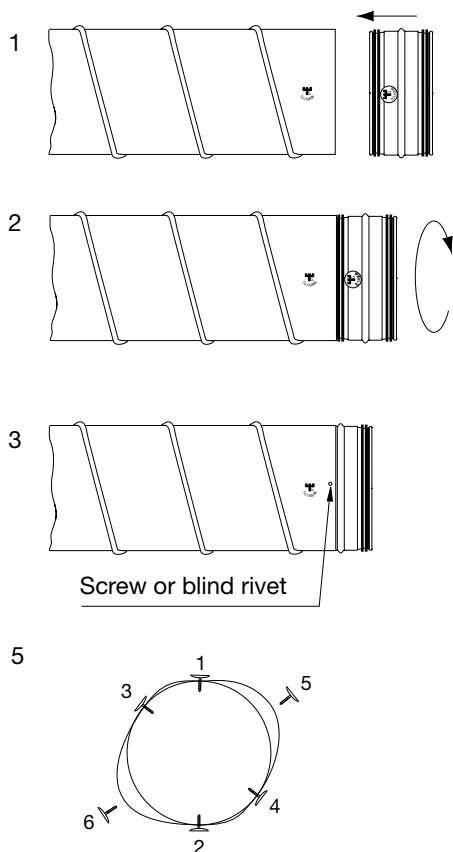



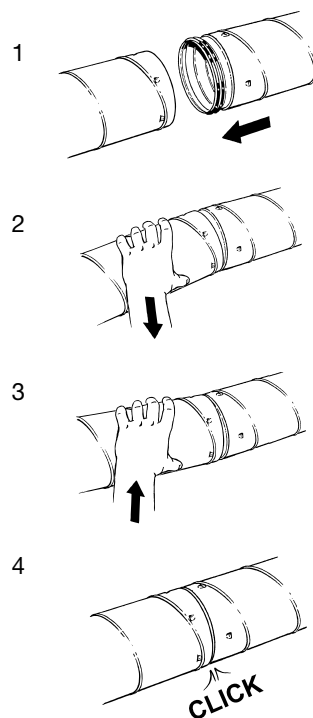

Lindab Safe Click

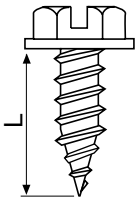
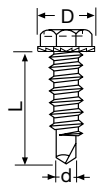

# Mounting instruction

# Lindab Safe

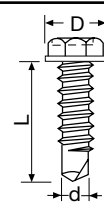
**Table 4. Screws and blind rivets**

		Allowed by Lindab	Not allowed by Lindab
	<p>Screw with sharp tip</p> <ul style="list-style-type: none"> <li>• Very tight</li> <li>• Strong since it forms a collar in the thin sheet metal</li> </ul>	✓	
	<p>Screw with reduced drill tip</p> <ul style="list-style-type: none"> <li>• Very tight</li> <li>• Strong since it only drills off a small part of the thin sheet metal</li> </ul>	✓	
	<p>Pressure-tight blind rivet</p> <ul style="list-style-type: none"> <li>• Very tight</li> <li>• Strong</li> <li>• Very laborious to install</li> </ul>	✓	
	<p>Screw with drill tip</p> <ul style="list-style-type: none"> <li>• Not tight</li> <li>• Weak since it drills off a big part of the thin sheet metal</li> </ul>		✓
	<p>Blind rivet</p> <ul style="list-style-type: none"> <li>• Not tight if the inner splint falls out</li> <li>• Strong</li> <li>• Laborious to install</li> </ul>		✓

**Hints!**

Because of their weight, large heavy fittings in particular have a tendency to be slightly oval, however when suspended in brackets, they revert back to their round original shape.

For ducts ranging from Ø400 mm and up, Lindab has moved the gasket away from the coned edge, making the assembly safer and easier.

If you are reinstalling a product, always seal any old holes left from screws or blind rivets as the holes otherwise can cause air leakage and unnessecary noise.



# Mounting instruction

# Lindab Safe

## Before final assembly

Temporarily assemble the products before fastening to ensure that the correct length of duct or system is being used.

Lindab Safe	Lindab Safe Click
<p>Join the products and place where they are intended to be mounted</p> <p><b>If the duct or system is too long:</b> Disassemble the products and cut the ducts to require length if necessary</p> <p><b>If the duct or system is too short:</b></p> <ol style="list-style-type: none"> <li>1 Use products with sliding property. For example slide-in coupling SNPU or slide-in female coupling SMFU.</li> <li>2 Join together with screws or blind rivets.</li> </ol>	<p>Join the products and place where they are intended to be mounted. NOTE! Do not click-join together.</p> <p><b>If the duct or system is too long:</b> Disassemble the products and cut the ducts to require length and make new notches if necessary</p> <p><b>If the duct or system is too short:</b></p> <ol style="list-style-type: none"> <li>1 Use products with sliding property. For example slide-in coupling SNPU or slide-in female coupling SMFU.</li> <li>2 Join together with screws or blind rivets.</li> </ol>

Slide-in coupling

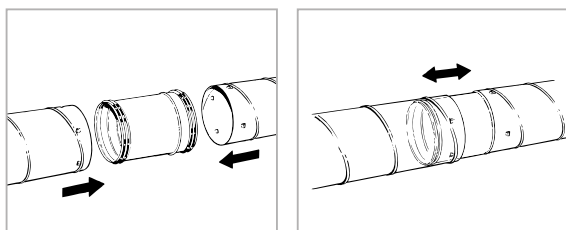

Slide-in female coupling

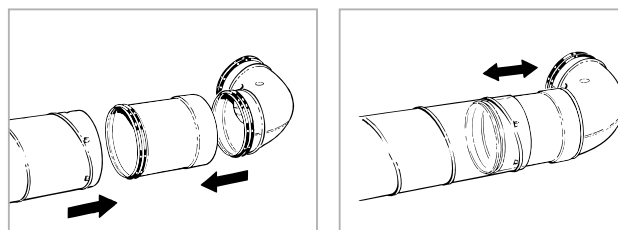

### Locking the joints

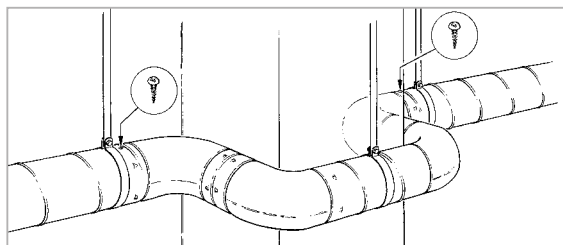

In situations where the mounting must be locked, e.g. when a bend is mounted to a duct and it twists downwards the floor; mount the first hanger and the bend, then lock the joint with a screw or blind rivet.

### Corners out of angle and curved walls

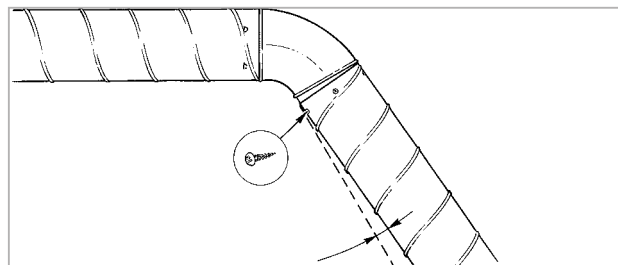

Mount the next piece of duct at an angle, but make sure that the rubber sealant is not visible. Put screws or blind rivets where the notches have not clicked in position.

### Suspension

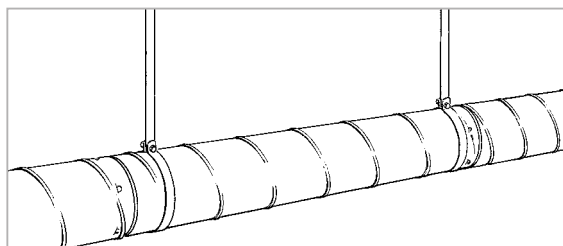

Mount the hangers in a straight line and as close to every joint as possible. Fix with an extra screw when needed for extra stability.

# Mounting instruction

# Lindab Safe

## Dismantling

To separate joined products.	
Lindab Safe	Lindab Safe Click
1 Unscrew the screws or drill away the blind rivets.	1 Drill a 5 mm hole in the duct 4 mm behind the notch with the drill angled backwards and at the same time turning the drill back to separate the fitting and duct.
2 Twist the product loose.	3 Repeat where necessary.
3 Carefully seal the holes with mastic or tape to be able to reuse the product.	4 Twist the product loose.
	5 Cut away the drilled-through duct end.
	HINT! With the right technique the product remains undamaged and can be reused.

### Lindab Safe Click

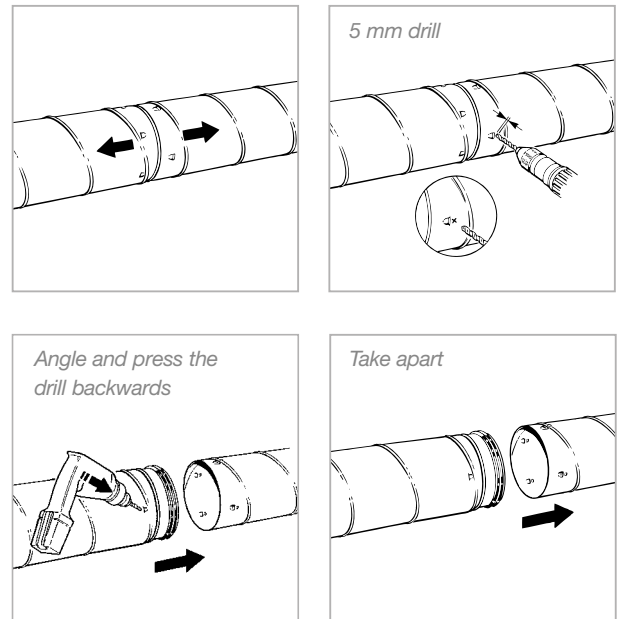

### Products with special seals

Some fittings, such as the collar saddle PSU, T-pieces TSTCU, TSTU and take-offs ILRU, ILU, ILF, have a different connection than Lindab Safe or Lindab Safe Click. Using these products, the connections must be sealed so that they meet the requirements for air-tightness class C or D. The sealing material used must be durable and permanently elastic.

### Products without Click

Some fittings, such as the slide-in female coupling SMFU, the end caps EPF and ESU and the cleaning covers EPFH, ESHU, KCU and KCIVU, do not have the Click function in order to make them easy to remove.

### Use of products other than Lindab Safe or Lindab Safe Click

Products that do not formally fulfil the requirements for air tightness class C or D may only be used to a small extent. If such products are used, they must be carefully checked with regard to seal design and strength. Using these products, the connections must be sealed so that they meet the requirements for air-tightness class C or D. The sealing material used must be durable and permanently elastic.



Most of us spend the majority of our time indoors. Indoor climate is crucial to how we feel, how productive we are and if we stay healthy.

We at Lindab have therefore made it our most important objective to contribute to an indoor climate that improves people's lives. We do this by developing energy-efficient ventilation solutions and durable building products. We also aim to contribute to a better climate for our planet by working in a way that is sustainable for both people and the environment.

[Lindab](#) | For a better climate